

CONTENTS

1 MARKINGS, APPLICABLE STANDARDS and SAFETY INSTRUCTIONS

SAFETY, MAINTENANCE AND MOUNTING INSTRUCTIONS

Volans Ex-db Cable gland series
Types VOL..., VOLC..., VOLF..., VOLM..., VOLS..., VOLSC..., VOLSF..., VOLSM..., CESI 21 ATEX 031 X IECEx CES 22.0009X



Rev. 01

- 1 MARKINGS and APPLICABLE STANDARDS
- 2 PREPERATION of CABLES
- 3 IP PROTECTION for NON-THREADED HOLE
- 4 IP PROTECTION for THREADED HOLE
- 5 TORQUE TABLE
- 6 EU DECLARATION OF CONFORMITY
- 7 PRODUCT SUB PARTS
- 8 PRODUCT SUB PARTS
- 9 PRODUCT SUB PARTS
- 10 PRODUCT SUB PARTS
- 11 MOUNTING INSTRUCTION
- 12 MOUNTING INSTRUCTION
- 13 MOUNTING INSTRUCTION
- 14 MOUNTING INSTRUCTION

MARKINGS

Product code for VOL..., VOLC..., VOLF..., VOLM..., VOLS..., VOLSC..., VOLSF..., VOLSM... serie	
Group I	CE 0722 Ex db I Mb; Ex eb I Mb IP66/68 Ta -60°C to +130°C CESI 21 ATEX 031 X IECEx CES 22.0009X
Group II, III	CE 0722 Ex db IIC Gb; Ex eb IIC Gb; Ex tb IIC Db IP66/68 Ta -60°C to +130°C CESI 21 ATEX 031 X IECEx CES 22.0009X

APPLICABLE STANDARDS

DIRECTIVE 2014/34/EU		
EN IEC 60079-0:2018	IEC 60079-0:2017 Ed.7.0	IEC 60529:1989
EN IEC 60079-7:2015+A1:2018	IEC 60079-7:2014-06 Ed.7.0	EN 60529:1991
EN 60079-1:2014	IEC 60079-7:2017 Ed.5.1	
EN 60079-31:2014	IEC 60079-31:2013 Ed.2	

SAFETY INSTRUCTIONS

- * Changes to products are not allowed.
- * Only BIMED spare parts must be used.
- * Everyday and extraordinary maintenance operations must be carried out only by qualified personnel after approval from expert technicians.
- * Cable glands are only suitable for fixed installations.
- Cables shall be effectively clamped to prevent pulling or twisting.
- ‡ The cable glands can be used with Ex i intrinsically safe circuits.
- The cable gland installation shall be done according to safety manufacturer instructions to maintain degree of protection.
- * The end user shall ensure that the surface finish of the enclosure is smooth enough to obtain the required IP rating.
- * It is recommended for enclosure entries to be perpendicular, circular and free of burrs.
- * For non threaded enclosure applications, the end user shall respect the recommended hole diameters mentioned in the mounting instruction.

Please refer to the figure below, for details about the preparation of steel wire armour, braided and metal tape shielded cables for fitting into the cable gland.

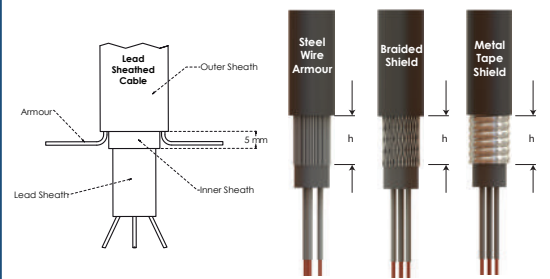

CABLE GLAND SIZE	M12, M16, M14, M20, M20, M25, M25, M32, M32, M40S	M40, M50, M50, M63, M63, M75, M75, M80S, M90S	M80, M90, M100S, M100
CABLE STRIP LENGTH "h"	20 mm	25 mm	32 mm

3 IP PROTECTION for NON-THREADED HOLE

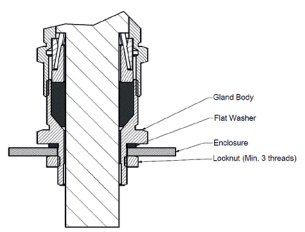

Recommended Hole Diameters For Non Threaded enclosure applications in relation with the used thread types are shown below.

METRIC THREADS		G THREADS(GAS ISO 228/1)		PG THREADS	
THREADS	HOLE DIAMETER (min-max mm)	THREADS	HOLE DIAMETER (min-max mm)	THREADS	HOLE DIAMETER (min-max mm)
M12 x 1.5	Ø12.0-12.5	G 3/8"	Ø16.6 - 16.8	PG 7	Ø12.5 - 12.7
M16 x 1.5	Ø16.0-16.5	G 1/2"	Ø21.0 - 21.2	PG 9	Ø15.2 - 15.4
M20 x 1.5	Ø20.0-20.5	G 3/4"	Ø26.4 - 26.6	PG 11	Ø18.6 - 18.8
M25 x 1.5	Ø25.0-25.5	G 1"	Ø33.3 - 33.6	PG 13.5	Ø20.4 - 20.6
M32 x 1.5	Ø32.0-32.5	G 1 1/4"	Ø41.9 - 42.2	PG 21	Ø28.3 - 28.5
M40 x 1.5	Ø40.0-40.5	G 1 1/2"	Ø47.8 - 48.1	PG 29	Ø37.0 - 37.3
M50 x 1.5	Ø50.0-50.5	G 2"	Ø59.6 - 59.9	PG 36	Ø47.0 - 47.3
M63 x 1.5	Ø63.0-63.5	G 2 1/2"	Ø75.2 - 75.5	PG 42	Ø54.0 - 54.3
M75 x 1.5	Ø75.0-75.5	G 3"	Ø87.9 - 88.2	PG48	Ø59.3 - 59.6
M80 x 1.5	Ø80.0-80.5	G 3 1/2"	Ø100.4 - 100.7		
M90 x 1.5	Ø90.0-90.5	G 4"	Ø113.1 - 113.4		
M100 x 1.5	Ø100.0-100.5	G 5"	Ø138.5 - 138.8		
M110 x 1.5	Ø110.0-110.5				
M115 x 1.5	Ø115.0-115.5				

4 IP PROTECTION for THREADED HOLE

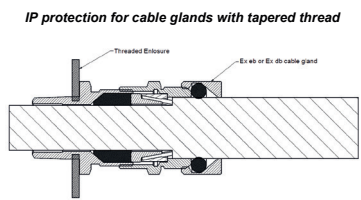

- Remarks
- > **Ingress Protection:** In order to guarantee the specified IP66/68 rating, sealant agent shall be applied on at least two full threads before fitting the gland to the box. In any case you must pay attention to guarantee the metallic continuity.
 - > **Assembling on Ex db enclosures:** The enclosure wall has to be thick enough to engage at least 5 full threads.

IP protection mode for cable glands with cylindrical thread

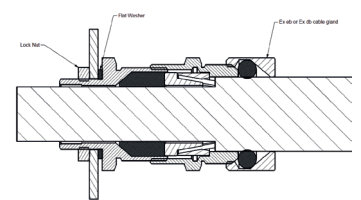

- Remarks
- > **Ingress Protection:** In order to guarantee the specified IP66/68 rating, it is recommended to use flat washer between the gland body and enclosure
 - > **Assembling on Ex db enclosures:** The enclosure wall has to be thick enough to engage at least 5 full threads.
 - > **Assembling on Ex eb or Ex tb enclosures:** You have to respect a minimum wall thickness of 1.5.

5 TORQUE TABLE

Torque table for cable gland models VOL..., VOLC..., VOLF..., VOLM..., VOLS..., VOLSC..., VOLSF..., VOLSM...,

Clamping Range	Torque of cable glands [Nm]	
	Min.-Max.	SW2 SW3
5,5-12,0	15	15
9,0-16,0	20	20
12,0-20,0	20	20
16,0-26,0	20	20
20,0-33,0	25	25
29,0-41,0	50	50
36,0-52,0	55	55
50,0-65,0	100	100
61,0-78,0	125	125
75,0-89,0	200	200
75,0-89,0	200	200
88,0-104,0	270	270

6 EU DECLARATION OF CONFORMITY

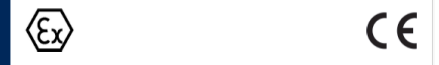

EU DECLARATION OF CONFORMITY



Bimed Teknik Aletler San. ve Tic. A.Ş.
Özar Sanayi Bölgesi, Deliklikaya Mh. Yüzbaşı Mehmet Hilmi Cd. No.28/1 Amavutköy - İstanbul / TÜRKİYE Tel: +90 212 87573 76 Fax: +90 212 875823

declares that the products designed to be placed on the market for use in the explosive atmospheres described below are in conformity with the listed EU Directive and harmonized standards.

Cable Gland Types:	VOL..., VOLC..., VOLF..., VOLM..., VOLS..., VOLSC..., VOLSF..., VOLSM...
Certificate Number:	CESI 21 ATEX 031 X
Protection Type :	⊕ I M2 Ex db I Mb Ex eb I Mb ⊕ IIGD Ex db IIC Gb, Ex eb IIC Gb, Ex tb IIC Db IP66/68

EU Directive:	ATEX 2014/34/EU
The harmonized standards applied:	EN IEC 60079-0:2018 EN 60079-1:2014 EN IEC 60079-7:2015/A1:2018 EN 60079-31:2014

Notified body CESI 0722

İstanbul, 02.10.2025

General Manager
Yakup Güllühal
BİMED TEKNİK ALETLER SAN. VE TİC. A.Ş.
SARAYCIYI MAHALLESİ
SARAYCIYI MAHALLESİ

7 Detailed Sub-Parts for Cable gland type VOL

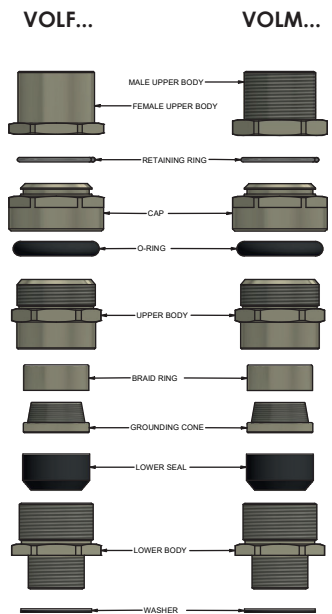

8 PRODUCT SUB PARTS

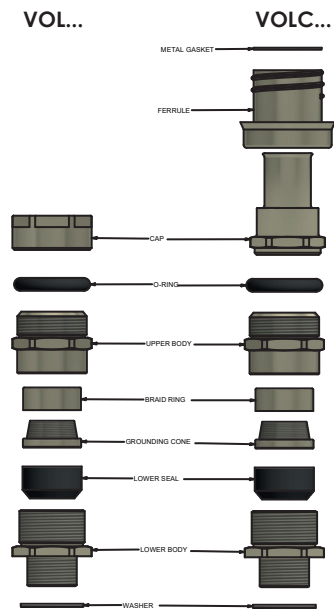

9 PRODUCT SUB PARTS

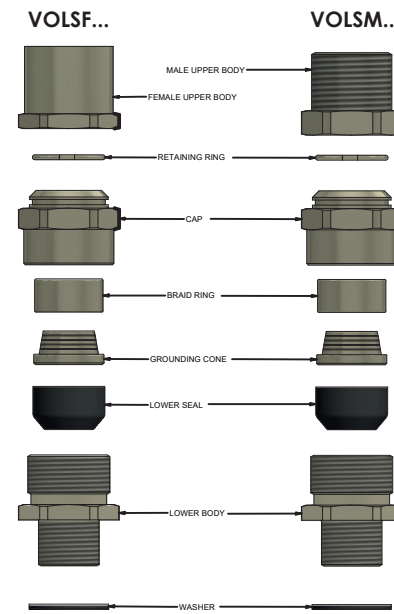

10 PRODUCT SUB PARTS

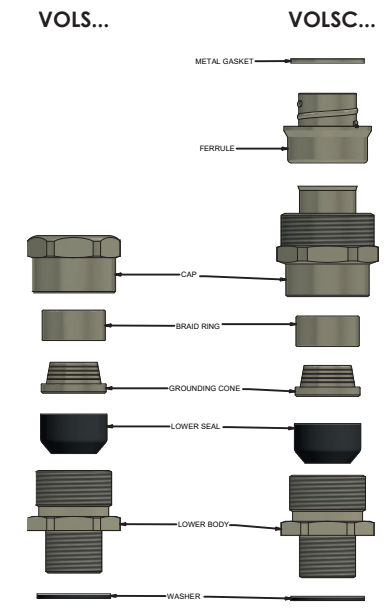

Rev. 0

11 MOUNTING INSTRUCTIONS

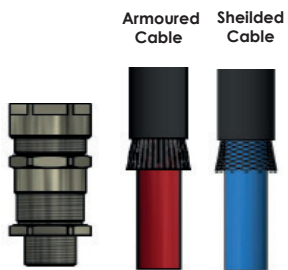

Step 1 - Choose the optimal cable according to clamping ranges submitted in the certificate and prepare the cable for installation. All sub-parts required for installation are shown respectively above.

12 MOUNTING INSTRUCTIONS

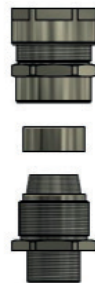

Step 2 - Separate lower body and upper body from each other so that ensure grounding cone is visible in the lower body. Mount the lower body to the appropriate opening on enclosure and tighten with sufficient torque value. Use locknut to tighten if the enclosure is non-threaded.

13 MOUNTING INSTRUCTIONS

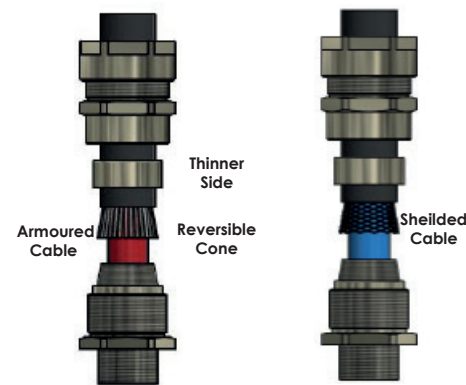

Step 3 - Insert the cable to the inside of upper body. Pay attention to the direction of the Reversible cone. If steel wire armoured cable is mounted, cable armours must be clamped with thinner side of the reversible cone.

14 MOUNTING INSTRUCTIONS



Step 4 - Tighten the upper body with sufficient torque value. For torque values please refer the tables "Sizes and torque of cable glands". Visually check if armour is securely clamped. If not, repeat the clamping process.